



Super Touring 1-4 (ST1, ST2, ST3, ST4 & Super Unlimited)

Official 2021 National Rules

(Rules subject to change)

Nov. 30, 2020, Version 15.1

© 2003–2021

1	Introduction	4
2	Intent	4
3	Sanctioning Body	5
4	Eligible Manufacturers/Models/Configurations	5
	4.1 Super Unlimited (SU).....	5
	4.2 Super Touring (ST1, ST2, ST3, ST4).....	5
5	Safety	6
	5.1 Super Unlimited (SU).....	6
	5.2 Super Touring (ST1, ST2, ST3, ST4).....	7
	5.3 On Course Conduct.....	7
6	Modifications (ST1, ST2, ST3, ST4)	7
	6.1 Restrictions and Limitations for All Vehicles.....	7
	6.1.1 Active Aerodynamic devices.....	7
	6.1.2 Fuel.....	8
	6.1.3 Transmissions.....	8
	6.1.4 Tires.....	8
	6.1.5 Ballast.....	8
	6.1.6 Power Alteration & Wireless Hardware.....	8

6.1.7	Tube-frame Chassis Conversion.....	8
6.2	Restrictions and Limitations for All Production Vehicles.....	8
6.2.1	Chassis and Body Modifications to Production Vehicles.....	8
6.2.2	Production Vehicle Aerodynamics (ST1, ST2, ST3).....	10
6.3	ST4 and ST3 Production Vehicle “BTM Aero” Modification Factor.....	10
6.4	ST4 Specific Restrictions and Limitations.....	11
6.4.1	ST4 Tire Limitations.....	11
6.4.2	ST4 Aerodynamic Modification Restrictions and Limitations.....	12
6.4.3	ST4 Anti-Lock Braking Systems (ABS).....	13
6.5	“Adjusted Weight/Power Ratio” Calculation	13
6.5.1	Definitions (inc. NASA Section Width).....	13
6.5.2	Modification Factors.....	14
6.5.3	Non-Production Vehicles Approved for ST4.....	16
6.5.4	Example Calculations.....	17
7	Dyno Testing	18
7.1	Dyno Testing Procedures.....	18
7.2	Average Horsepower Calculation.....	20
7.2.1	Vehicle redline greater than 7000 rpm.....	20
7.2.2	Vehicle redline between 6000-7000 rpm.....	21
7.2.3	Vehicle redline less than 6000 rpm.....	21
7.3	Dyno Compliance Inspections.....	21
8	Forms, Inspections, Protests, Penalties	23
8.1	ST/TT Car Classification Forms.....	23
8.2	Vehicle Inspection.....	24
8.3	Protests.....	25
8.4	Penalties.....	25
8.4.1	Regional.....	25
8.4.2	National.....	25
8.4.3	Procedural Violations.....	26
9	Vehicle Appearance	26
9.1	Car Numbers and Class Designation.....	26
9.2	General Car Appearance.....	26
9.3	Rear Brake Light Requirement.....	26
	Appendix A—Technical Bulletins for Specific Models/Items	27
	Chevrolet Corvette C5 & C6.....	27
	CTSC Tires.....	27
	Factory Five Roadster and Backdraft Cobra.....	27
	Ford Mustang (ABS in ST4).....	27

Ford Mustang and BMW E36 M3.....	28
Mazda Miata ('90-'05).....	28
NASA NP01.....	28
Nissan 350Z/370Z.....	28
Thunder Roadster tires.....	28
Thunder Roadster pre-'08 body/no-wing type.....	28
Appendix B—BTM Aero Modification Factor non-BTM approvals.....	29

(See separate file for NASA Section Width Tire Measurement Tools)

(Note: Latest revisions are in **Blue** font, and all previous revisions are in **light green**)

1. **Introduction**

NASA Super Touring (ST) and NASA Super Unlimited (SU) are automobile road course (circuit) competition series focused on road course competition, and shall function as an advertising and marketing tool for the series sponsors, the independent sponsors of each team, as well as the official sanctioning body of the series. The trade names “NASA Super Touring[®] (ST)” and “NASA Super Unlimited (SU)” and these rules are the property of the National Auto Sport Association, Incorporated[®]; located at: 7065 W Ann Rd. #130 – 432, Las Vegas, NV 89130; 510-232-NASA (6272).

NASA ST/SU provides a venue for spirited on-track competition in high performance race cars of all makes, models and types. Several key factors are considered in classing vehicles in ST, using an “Adjusted Weight/Power Ratio” as the ultimate equalizer between vehicles. The relatively few modification specific rules will allow competitors to configure their cars to perform at an optimal level by using aftermarket parts, providing an opportunity for promotional exposure for the competitors’ sponsors, aftermarket tuners, parts manufacturers, and the vehicle manufacturers. Additionally, these series should provide a stage to showcase driving talent, in hopes that the most talented drivers will advance to even higher-level professional series. The format of the rules encourages direct crossover from both NASA TT classes and race classes from other organizations.

There are six Super Touring classes—Super Touring 1, (ST1), Super Touring 2 (ST2), Super Touring 3 (ST3), Super Touring 4 (ST4), Super Touring 5 (ST5), and Super Touring 6 (ST6), with ST1 being the highest performance level class of the six, and ST6 being the most restrictive. Super Unlimited (SU) is a class with no performance modification restrictions. These rules pertain only to the Super Unlimited and Super Touring 1-4 classes (please see “Super Touring 5-6” rules for the ST5 and ST6 class rules). An “Adjusted Weight/Power Ratio” modified based on competition weight, tires, chassis/body, transmission, drivetrain (and aerodynamic modifications for ST3 and ST4 only) is used to equalize cars in each of the Super Touring classes.

2. **Intent**

The intent of these rules is to provide mandates to ensure that all Super Touring vehicles are modified within clearly established limits to strive for an even platform in which a contest of driving skill may provide the most talented drivers with great rewards. The rules shall be applied in a logical manner that seeks to provide competitors a safe and fair venue for competition, without a constrained interpretation of the rules based on phraseology or verbiage.

Rule changes will be announced via Technical Bulletins published in the Super Touring section of the <https://community.drivenasa.com> website and/or the NASA Super Touring website <https://supertouring.nasaseries.com/> .

3. Sanctioning Body

The NASA ST/SU series is supported and sanctioned by the National Auto Sport Association (NASA). All race events are governed by the rules set forth by the Race Directors, National Series Directors, and NASA Officials. All competitors must also abide by the rules set forth in the current Club Codes and Regulations (CCR) and any supplemental rules issued by Race Directors, Regional Directors, or National Series Directors.

4. Eligible Manufacturers/Models/Configurations

4.1 Super Unlimited (SU)

Any non-formula vehicle that passes NASA safety tech inspection based on the specifications found in the CCR may compete in Super Unlimited. As well, alternative vehicles may be permitted provided that they meet the current specification from other sanctioning bodies enumerated in the CCR. There are no maximum power limits or minimum weight limits. Any type and size tires may be used. All types of motors, transmissions, chassis, frames, bodies, suspensions, aerodynamic modifications, and braking systems are permitted. (Note: No modification rules or limitations in Section 6)

4.2 Super Touring (ST1, ST2, ST3, ST4)

Any four-wheel, fendered/closed-wheel, internal combustion engine vehicle that passes NASA safety technical inspection can be used to compete in Super Touring provided it is in compliance with the modification limitations in section 6 of these rules. Hybrids must be approved by the National ST Director. (Possible future EV eligibility pending)

Sports racers, “Prototypes”, and monocoque chassis purpose-built race cars are permitted in ST1 and ST2 using the specific Modification Factor listed for these chassis in 6.5.2. They are not permitted in ST3 or ST4 unless specifically approved elsewhere in these rules, or by written approval of the National ST Director.

“Production” vehicle models are those manufactured by an automobile manufacturer (at least 500 produced per year) for and approved for street use by the U.S. D.O.T., T.U.V, or Japanese government, provided it is in compliance with the modification limitations in section 6.1 and 6.2 of these rules. (Other approved vehicles are listed in 6.5.3)

“Non-Production” vehicles (ST1, ST2, and ST3 only), include all other ST series eligible vehicles including “kit” cars, purpose-built track/race cars, tube-frame and partial tube-frame conversion vehicles, and “Production” vehicles that have modifications not in compliance with section 6.2, and will be assessed the “Non-Production Vehicle” Modification Factor listed in 6.5.2 unless the vehicle model is listed in Section 6.5.3 of these rules and has been approved to

compete under “Production” vehicle status. A competitor with a vehicle originally qualified as a “Production” model may use the Modification Factor assessment for “Non-Production Vehicle” to avoid all “Production vehicle only” limitations/restrictions in section 6.2.

For ST4, all vehicles must originate as Production street vehicles unless listed otherwise in Section 6.5.3. Tube frame chassis conversions are not permitted. The Non-Production Vehicle Modification Factor may not be utilized in ST4, but additional specific Modification Factor assessments for certain approved non-production modifications are listed in 6.5.2.

All competition is based on the “Adjusted Weight/Power Ratios” (section 6.5) below:

Super Touring 1 (ST1) = “Adjusted Wt/HP Ratio” equal to, or greater than, **6.00:1**

Super Touring 2 (ST2) = “Adjusted Wt/HP Ratio” equal to, or greater than, **8.00:1**

Super Touring 3 (ST3) = “Adjusted Wt/HP Ratio” equal to, or greater than, **10.00:1**

Super Touring 4 (ST4) = “Adjusted Wt/HP Ratio” equal to, or greater than, **12.00:1**

The National ST Director will determine and publish any additional Modification Factor(s), limitations, and/or restrictions placed on specific vehicle models.

5. Safety

5.1 Super Unlimited

All rules in Section 15 and 18 of the NASA CCR shall apply, with the following exceptions that shall supersede those in the CCR:

CCR 15.6—Roll cages may be built to provide an unlimited amount of chassis stiffening. Any number of cage mounting points above the minimum required can be used. Any number of additional tubes, including those penetrating the firewall or those converting the vehicle into a tube-frame chassis vehicle are permitted.

CCR 15.10—Front driver and passenger side fixed/Lexan windows are permitted if they are: 1) factory installed during the manufacturing of the vehicle, or 2) if they are made of non-shattering material (Lexan), can be removed from both the inside and outside of the vehicle with no tools required, and allow the driver to comply with the driver emergency exit time requirements in the CCR.

CCR 18.3—Any type of fuel or additives that are approved by the Race Director are permitted.

CCR 18.7—Tire grooving is permitted in Super Unlimited.

5.2 Super Touring (ST1, ST2, ST3, ST4)

All rules in Section 15 of the NASA CCR shall apply, with the following exceptions that shall supersede those in the CCR:

CCR 15.6—Roll cages may be built to provide an unlimited amount of chassis stiffening. Any number of cage mounting points above the minimum required can be used. Any number of additional tubes, including those penetrating the firewall are permitted. Additional tubes converting the vehicle into a tube-frame chassis vehicle are permitted in ST1, ST2, and ST3.

CCR 15.10—Front driver and passenger side fixed/Lexan windows are specifically not permitted unless they are factory installed during the manufacturing of the vehicle. Both front side windows must otherwise be in the down position while on track.

5.3 On Course Conduct

Any driver displaying rough, careless, and/or irresponsible driving or displaying unsportsmanlike conduct may receive harsh penalties, which may include loss of points, suspension, and/or monetary fines at the discretion of NASA Officials.

In addition to the passing/punting rules in the NASA CCR:

Along any straight section of the track, if attempting to pass or attempting to prevent a pass, a driver that forces another competitor to drive off the racing surface in order to prevent car-to-car contact will be penalized by the Race Director. The penalty will be solely at the discretion of the Race Director, but the suggested minimum penalty for such a dangerous and unsportsmanlike maneuver is disqualification and a one race suspension.

6. Modifications (ST1, ST2, ST3, ST4)

Unless listed otherwise, performance enhancing modifications are unlimited.

6.1 Restrictions and Limitations for All Vehicles

All Super Touring vehicles must adhere to the following modification restrictions and limitations (6.1.1 through 6.1.7).

6.1.1 Active aerodynamic devices and/or modifications (including, but not limited to, computerized, cockpit adjustable, self-adjusting, and OEM) are not permitted. Aerodynamic devices and/or modifications may not protrude more than six (6") inches from the vertical plane from the ground to the widest part of the right and left sides of the vehicle's body. Front wing/spoiler/foil/splitter may not protrude more than 12 inches in front of the outermost edge of the front bodywork/fascia, and may not be higher than the lowest part of the vehicle's hood.

6.1.2 Nitrous Oxide use is prohibited. Pre-existing tanks must be removed. Methanol/Alcohol-water injection is permitted provided that the mixture does not exceed 50% alcohol by volume. Methanol is not permitted as a fuel. (See CCR 15.19 and 18.3)

6.1.3 Sequential, paddle shift/semi-automatic, and dog-ring/straight-cut gears (i.e. non-synchromesh) transmissions are permitted, but will be assessed via the “Adjusted Weight/Power Ratio” formula regardless of whether they are OEM or not.

6.1.4 Tire treatments and softeners are not permitted. Tire and wheel size are unlimited in ST1, ST2, and ST3, but non-DOT approved tires will be assessed via the “Adjusted Weight/Power Ratio”. Non-DOT approved tires are not permitted in ST4. DOT-approved R-compound autocross tires shall be assessed via the “Adjusted Weight/Power Ratio” in ST4. Maximum tire size in ST4 is limited. (See ST4 specific limitations in 6.4)

6.1.5 Up to two hundred and fifty (250) lbs. of added ballast is permitted. All ballast must be of solid material (no fluids or shot pellets), safely secured in any location on the vehicle not disallowed by NASA safety technical inspectors, and comply with Section 15.20 of the NASA CCR.

6.1.6 From the start of qualifying through the end of post-race inspection, vehicles may not have any adjustments or modifications made to systems that could alter chassis dynamometer readings by changing horsepower levels (without the direct approval of the Race Director.) **Any hardware that allows a competitor or crew member to wirelessly or directly connect to the ECU (or alter ECU maps) at any time during competition or post-competition impound is strictly prohibited, regardless of whether such hardware is external or internal to the ECU, and regardless of the direction of data flow.**

6.1.7 Tube-frame chassis conversion (partial or complete) is permitted in ST1, ST2, and ST3, but all tube-frame chassis conversion vehicles will be assessed the Modification Factor for “Non-Production” vehicles, and subsequently, none of the other rules specifically for “Production Vehicles Only” will apply (6.2). If a vehicle cannot be driven safely, at full speed, with any of the added tubes removed, it is considered a tube-frame chassis conversion.

6.2 Restrictions and Limitations for All Production Vehicles (only)

The following rules do not apply to any ST1, ST2, or ST3 vehicle that is taking the Modification Factor assessment for “Non-Production Vehicle”, regardless of whether or not the vehicle was originally a Production vehicle. “OEM” is defined as any part that comes from the vehicle manufacturer either as a standard feature, a factory option, or on a factory optional trim model/package of that generation of the street-legal (in the U.S.A.) version of the vehicle.

6.2.1 Chassis and Body Modifications to Production Vehicles

Other than the listed exceptions, every Production vehicle must retain its unmodified:

- 1) OEM frame rails/rear frame cross beam, and/or Unibody, and Sub-frames/suspension cross-members (in their OEM locations).
- 2) Strut/shock towers
- 3) Inner/inboard side of the fender wells (any non-horizontal aspect)
- 4) Rocker Panels
- 5) Transmission tunnel
- 6) Floor pan
- 7) Windshield frame location

The following are permitted exceptions to 6.2.1 above:

1a) Frame rails, sub-frames/suspension cross-members, and unibodies may have maximum diameter 0.75” (3/4 inch) holes drilled into them for purposes other than lightening, such as for the attachment of ancillary parts. Cutting and channeling is not permitted.

1b) Frame rails may have maximum diameter 1.25” (1-1/4 inch) holes drilled solely for the purpose of the placement of jacking lugs/plates.

1c) Suspension sub-frames/suspension cross-members may be updated or backdated utilizing any OEM factory produced item that is a direct replacement piece for that model, regardless of year or street legality, provided that it can be installed in the same location and in the same manner as on the donor vehicle without modifications.

1d) Relocation of suspension mounting points is permitted in ST1, ST2, and ST3, provided that the modifications do not violate any of the other rules above. One possible method is via the use of modified mounting point brackets attached to OEM mounting locations. Relocation of suspension mounting points including “drop spindles” (spindles that have had the axle shaft relocated upward), is not permitted in ST4 except for: 1c. above, conversion from coil spring/leaf spring/torsion bar to coilover shock spring, and the addition of a panhard bar, torque arm, and/or watts link. Bump steer kits and replaced/modified control arm ball joints are permitted. Note: ball joint may be welded to the spindle for added strength].

1e) Modifications of non-subframe/non-suspension cross-members (other than the rear frame cross beam), transmission mounts, differential mounts, and radiator core supports are permitted.

1f) Modification of the OEM front bumper frame cross beam is permitted if a modified or replaced bumper beam remains that is equally strong for crash protection.

1g) Modification and/or relocation of components of the firewall with engine relocation ten (10) inches or less (i.e. no mid or rear engine conversion) is permitted, but is significantly limited by the requirement to retain the unmodified transmission tunnel and floor pan.

1h) Reinforcement of suspension mounting locations on OEM frame rails, Sub-frames/suspension cross-members, and unibody is permitted provided there is no performance benefit or relocation of the mounting points. Seam welding of the body is permitted.

1i) "B" pillars of the unibody may be notched to accommodate the placement of roll cage door bars provided that the notched area is welded to the bar(s) that intrude into the B-pillar.

2a) Strut tower reinforcement plate and/or bar(s) addition is permitted.

2b) Slotting and removal of material from the top surface of the OEM strut/shock tower to the extent necessary to allow simple camber/caster adjustment is permitted.

3) The inner/inboard side of the fender well (any non-horizontal aspect) may have holes cut specifically for the purpose of the passage of brake ducts, external shock reservoirs, air intake hose, and brake lines/ABS wires. Plastic fender liners may be modified and/or removed. If the fender well itself is constructed of plastic, it is not considered a "liner". The front, top, and rear aspects of the fender well may have modifications to allow vent holes for aero and/or cooling purposes (and specifically not for tire height clearance). As such, a component of the topmost aspect of the fender well must remain in the OEM location (but can be made of non-OEM material/venting). (note that ST4 has additional Aero limitations below in 6.3 and 6.4)

4a) Modification of the rocker panels solely for the placement of air jacks, pin stands, or jacking point reinforcement.

4b) Modification of the rocker panels for side-exit exhaust is permitted and will be assessed a Modification Factor in the "Adjusted Weight/Power Ratio."

5) The transmission tunnel may be modified for the purpose of installing a competition driver seat. The floor pan must remain in its original position.

6a) Modifications of the floor pan for purposes of exhaust clearance only is permitted and will be assessed a Modification Factor in the "Adjusted Weight/Power Ratio".

6b) Removal of the floor section of the rear hatch/trunk space and either replacement with a sheet metal cover or placement of a fuel cell is permitted without an additional Modification Factor.

6c) Floor pans may have maximum diameter 0.75" (3/4 inch) holes drilled into them for purposes of the attachment of ancillary parts, safety gear, seats, and for the passage of suspension components.

6d) Floor pan modifications to include items such as sub-frame connectors, atypical roll cage bracing, or alternate fuel cell placement may be approved on a case-by-case basis by the National ST Director, or included in Appendix A, and are subject to possible Modification Factor assessments.

6e) The floor under the driver's seat may be modified, and the OEM seat brackets/supports may be removed for the purpose of gaining head room for the driver. When inspected from the underside, the OEM floor pan must be unmodified."

7) Removal of the windshield and windshield frame is permitted, but will be assessed via the Modification Factor in the "Adjusted Weight/Power Ratio".

6.2.2 Production Vehicle Aerodynamics (ST1, ST2, ST3) (see 6.4 for ST4)

- 1) A rear wing (or rear spoiler for wagon-style bodies) may not exceed a height of eight (8) inches above the roof-line (or OEM windshield height for convertibles).
- 2) Modification of the OEM roof line and/or removal of the front windshield/frame is permitted, but will be assessed via a Modification Factor in the “Adjusted Weight/Power Ratio”.

6.3 ST4 and ST3 Production Vehicle “BTM Aero” Modification Factor

ST4 and ST3 Production vehicles that maintain the unmodified Base Trim Model (BTM) body lines, do not have non-BTM aerodynamic aides or modifications, and do not have a rear wing or rear spoiler or rear diffuser, may assess the Modification Factor for “BTM Aero” in calculating the “Adjusted Wt/HP Ratio”. Under this specific rule, an aerodynamic aide is considered non-BTM if it did not come configured on the base trim model (BTM) of the vehicle from the manufacturing factory. Except for those vehicle-specific higher level trim models (non-BTM) listed in Appendix B, there is no updating or backdating across trim models or the addition of dealer installed options permitted.

The following are permitted allowances/modifications for vehicles taking the Modification Factor assessment for “BTM Aero”:

- 1) Flat undertray/belly pan forward of the centerline of the front axle, extending no lower than the bottom of the front fascia.
- 2) Removal of a convertible soft top/frame and/or adding a hardtop to a convertible provided that the hardtop uses a sealed rear window and is either OEM, an OEM option, or the same shape and size of an OEM/OEM option top.
- 3) Lexan front, rear, and rear side windows without uncovered holes.
- 4) Front wing window/frame removal and/or replacement with Lexan.
- 5) Hood replacement/modification for venting and/or weight reduction only. Vent parts (including lips, flaps, air dams, louvers, insert mounting hardware) must not protrude more than 3/8” from the hood surface. (“aero” hood pins are permitted).
- 6) Removal/cutting/drilling of the fascia for engine cooling, air intake, brake ducting, and transponder mounting purposes.
- 7) Removal of rain gutters/drip edges, windshield wipers, and mirrors.
- 8) Rolled or flared fenders (includes add-on flares--only to the extent necessary to cover the tire as viewed from above—not viewed from the front or rear)
- 9) NACA ducts, air ducts, or air hoses placed in a side window frame solely for the purpose of driver cooling.
- 10) Headlamp, headlight covers, and fog lights may all be removed. The holes may be left open, used for brake ducts or engine air intake, or must be covered with material that replicates the shape of the BTM light/cover, leaving the shape of the BTM fascia intact.

6.4 ST4 Specific Restrictions and Limitations

6.4.1 ST4 Tire Limitations

1) Compound

Non-DOT approved tires are not permitted in ST4. DOT-approved R-compound autocross tires shall be assessed via the “Adjusted Weight/Power Ratio” in ST4. Hoosier DOT Wet tires shall be assessed as autocross tires except during an officially designated “Rain Session” when they may be used without a Modification Factor assessment. (Continental EC Wet—see App. A)

2) Size

(See 6.5.1 for “NASA Section Width” tire measurement specifications)

1) Vehicles with a Minimum Competition Weight greater than 3000 lbs. Must have a measured tire NASA Section Width equal to or less than 282mm.

2) Vehicles with a Minimum Competition Weight equal to or less than 3000 lbs. Must have a measured tire NASA Section Width equal to or less than 266mm.

6.4.2 ST4 Aerodynamic Modification Restrictions and Limitations

If not using the BTM Aero Modification Factor, aerodynamic parts/devices/aides shall be limited in ST4 to the following:

- 1) All of the items listed above in section 6.3 “BTM Aero” Modification Factor.
- 2) Vertical front air dam (5° tolerance) that follows or extends beneath the outermost edge of the front and side bodywork/fascia.
- 3) Single flat, horizontal front splitter (3/4” max. thickness) that protrudes no greater than 4” from where it intersects with the fascia or air dam. Along the entire splitter, there must be at least 1” of fascia or air dam material above/superior to where the splitter intersects the fascia/air dam, including at any air intake region.
- 4) Single rear wing or spoiler that does not exceed a height of 8” above the roof line, or width greater than the vehicle’s body width, or end plates with area greater than 144 square inches each, or 12” protrusion from the rear of the vehicle. Body width does not include flared fenders, mirrors, splitter, door handles.
- 5) Modified BTM, non-Base Trim Model (non-BTM), or replaced front fascia (unless specifically approved in Appendix B):
 - i) May have nothing attached to it other than specifically allowed items above.
 - ii) May not have canards/winglets molded into it.
 - iii) Any item that is molded into the fascia during the original manufacturing process that functions as an airfoil, deflector, dive plane, or vortex generator and extends 2” or more past the outline of the immediate surrounding fascia is prohibited. To inspect: a plumb line run across the entire surface of the fascia and bumper shall not have any such item that extends 2” past the line when viewed from above.
- 6) Cutting/removal of the rear bumper cover/fascia where it does not cover the rear frame/bumper cross beam.

7) Complete removal of both the windshield and windshield frame is permitted on OEM convertible top vehicles, but will be assessed the Modification Factor listed in section 6.5. The OEM cowl may be replaced with a flat cover between the hood and the dash, but no air deflectors may be added, and the entire cockpit must remain uncovered.

8) Convertibles may use aftermarket hardtops that are not compliant with 6.3.2 above, but they will be assessed with the Modification Factor for roofline/shape, may not extend rearward of the front edge of the OEM rear decklid, must have a sealed rear window, and the OEM windshield frame location must be preserved.

6.4.3 ST4 Anti-Lock Braking Systems (ABS)

Anti-lock braking systems may only be OEM or offered specifically for the car model (any trim model or generation) as a factory option. No OEM systems offered for a different car model or aftermarket systems are permitted, with the exception that the BMW E46 MK60 ABS (including Teves/ATE standalone) may be used on any vehicle.

6.5 “Adjusted Weight/Power Ratio” Calculation

6.5.1 Definitions

1) The “Adjusted Weight/Power Ratio” for each vehicle will be calculated based on a simple competition weight to average chassis dynamometer (Dyno) horsepower ratio (Wt/Avg HP), followed by the adjustment of the resulting ratio by adding to, or subtracting from it, based on the list of “Modification Factors” below. Competition Weight is defined as the minimum weight of the vehicle, with driver, any time that it competes in a qualifying session or race. Average horsepower calculation (Avg HP) is defined in Section 7.2.

2) All vehicle weights will be measured to the tenth of a pound (xxxx.x), and then rounded off to the nearest pound for all calculations. Any weight ending in “.5” (xxxx.5x) will be rounded up or down to the benefit of the competitor. All horsepower measurements will be rounded off to the nearest whole number, and any number ending in “.50” (xx.50x) or less will be rounded down. Any “Adjusted Weight/Power Ratio” calculation ending in “.995” (xx.995) or greater will be rounded up to the benefit of the competitor.

3) Non-DOT tire width is determined by the size number printed on the tire sidewall by the manufacturer.

4) “NASA Section Width”

DOT tire width is determined by a measurement of the “NASA Section Width” of the largest tire (if staggered sizes) on the vehicle in post-competition impound/inspection, without changes to tire inflation (may be allowed to cool to pre-competition pressure). The tire may be measured while off or on the vehicle at any location not affected by ground contact sidewall deflection. A tire's NASA Section Width is the measurement of the tire's width from its inner sidewall to its outer sidewall using the NASA Section Width tire measurement tool(s) (excluding any protective ribs, decorations or raised letters) at the point 30mm deep to the tread surface on a new tire.

If a worn tire on the vehicle is found to be out of compliance in impound, the competitor has the option to bring a new tire, on the same wheel type/size, and at the same tire pressure, to retest for compliance. Similarly, a competitor may protest another's worn tire thought to have been non-compliant at the start of competition. However, the protesting competitor may need to obtain the new tire and pay for dismount and mounting fees if a new tire/wheel combination is not readily available. If the tire is found to be non-compliant, those fees must then be paid by the competitor with the non-compliant tire.

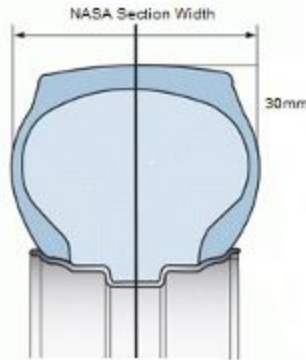

NASA Section Width tire measurement tools should be available at each NASA region technical inspection/impound area. The tool should fit loosely on the tire and not bind. It should fall if not being held in place. Additionally, templates for each tool size are available in a separate .pdf file on the NASA rules page.

NOTE! NASA Section Width measurement often DOES NOT correlate with the tire size printed on the tire by the manufacturer, and wheel width will change the NASA Section Width measurement. For example, a tire designated as a 275 by the manufacturer may not fit the 282mm NASA Section Width measurement tool. Use caution when selecting wheels and tires, and consult your regional series leader if you have questions.

5) All DOT-approved tires must be available for purchase by the general public through Federal or state licensed tire dealers.

6.5.2 Modification Factors

The “Modification Factor” listed after each item below is added or subtracted from the actual measured Wt/HP ratio to calculate the “Adjusted Wt./HP Ratio” which determines vehicle compliance in each ST class.

Competition Weight:

Less Than:

3000 lbs = -0.1	
2600 lbs = -0.2	
2200 lbs = -0.3	

Greater Than:

3300 lbs = +0.1	3600 lbs = +0.4
3400 lbs = +0.2	3750 lbs = +0.5
3500 lbs = +0.3	3900 lbs = +0.6

Tire Size:	DOT-approved:	
	NASA Section Width 266mm or smaller	= +0.6
	NASA Section Width 267mm to 282mm	= +0.3
	Non-DOT-approved:	
	Size 9.5"/241mm/24cm or smaller	= +0.6
	Size 10.5"/270mm/27cm to 9.6"/242mm/25cm	= +0.3
Tire Type:	Non-DOT approved tires (ST1, ST2 Only)	= -0.5
	Non-DOT approved tires (ST3 Only)	= -0.7
	Tires with a UTQG Treadwear rating 100 or greater or Toyo RR	= +0.6
	(Note: Any new tire model or upward treadwear revision after 12/10/17 requires NASA approval)	
	<u>ST4 Only</u> : DOT-approved R-comp Autocross tires	= -1.0
	(examples: A6, A7, DOT Wet, R1S, RS AC, Z214-C90/91)	
Chassis:	Sports racers, "Prototypes", monocoque race cars (ST1)	= -2.5
	Sports racers, "Prototypes", monocoque race cars (ST2)	= -3.4
	Other Non-Production Vehicle (ST1, ST2, ST3 only):	= -0.4
	Production Vehicle Body Modifications:	
	Modification of the OEM roof line/shape	
	and/or windshield/frame removal	= -0.3
	Modification of the floor pan for exhaust clearance only and/or	
	the rocker panel for side exit exhaust only	= -0.2
	<u>ST3 and ST4 Only</u> : BTM Aero (see 6.3)	= +0.4

Transmission:

ST1 & ST2: Dog-ring/straight-cut gears (non-synchromesh), and/or sequential/paddle shift/semi-automatic	= -0.2
ST3 & ST4: OEM dual clutch (ex. DCT, DSG, PDK), Dog-ring/straight-cut gears	= -0.5
ST3 & ST4: Other OEM street-legal model available paddle shift (ex. SMG), or sequential motorcycle gearbox	= -0.3
ST3 & ST4: All other sequential/semi-automatic	= -1.0

Drivetrain:

ST1, ST2, & ST3: AWD	= -0.3
ST1: FWD (non-Production Factory Built Race Car)	= +0.8
ST2: FWD (non-Production Factory Built Race Car)	= +0.5
ST3: FWD (non-Production Factory Built Race Car)	= +0.2
ST1, ST2, & ST3: FWD (all other)	= +1.0
ST4: AWD	= -0.5
ST4: FWD	= +0.6

6.5.3 Non-Production Vehicles Approved for “Production” Vehicle Status

The following vehicles are approved to use “Production” vehicle status, **provided that the frame/chassis, body/aero remain in the original manufactured configuration** as specified by the manufacturer (unless designated otherwise below). The “Chassis” Modification Factors and the “Production Vehicle Body” Modification Factors shall not be assessed, but the vehicle specific Modification Factor listed below for each model will apply. None of these vehicles are eligible for the “BTM Aero” Modification Factor. Only the vehicles designated “ST4 approved” may participate in ST4.

No Modification Factor Models:

Backdraft Cobra RT3 (no TD body/no Aero, no hardtop, FF Challenge air dam ok)	= -0.0
Dodge SRT10 Viper ACR-X (may have additional Aero mods)	= -0.0
Dodge Viper Competition Coupe (may have additional Aero mods)	= -0.0
Ferrari 348, 355, and 360 Challenge Series (ST1 & ST2 only)(may have additional Aero mods)	= -0.0
Factory Five Roadster (no aero, no hardtop, FF Challenge air dam ok)	= -0.0
Legends (may have additional Aero mods) (ST4 approved)	= -0.0
Mazda MX-5 Global Cup Racecar (may have additional Aero mods) (ST4 approved)	= -0.0
Porsche 996 GT3 Cup & 997 GT3 Cup (ST1 & ST2 only) (may have additional aero mods)	= -0.0
Thunder Roadster pre-'08 body/no-wing type (no aero mods) (ST4 approved only if using INEX TR specified tire—no assessment for the non-DOT tire Mod Factor)	= -0.0

With Modification Factor Models:

Allison Legacy (no additional aero mods) (ST4 approved)	= -0.2
Allison Legacy (with front air dam and/or 4” front splitter) (ST4 approved)	= -1.2
Baby Grand (no additional aero mods) (ST4 approved)	= -0.2
Backdraft Cobra RT3 (TD, hardtop, or any aero mods)	= -0.2
Brunton Stalker (no Aero mods)	= -0.2
Caterham 7, Lotus 7, Wesfield Super 7 (no aero mods)	= -0.2

Exomotive Exocet (no aero/wing/splitter)	= -0.2
Ferrari 430, 458 Challenge (ST1 & ST2 only) (may have additional aero mods)	= -0.2
Factory Five Roadster (if any aero mods, wing, or splitter)	= -0.2
Factory Five Roadster (no aero, no hardtop, FF Challenge air dam ok) (ST4 approved)	= -0.6
Factory Five Type 65 Coupe (Gen 1&2) (no additional aero mods)	= -0.2
Factory Five Type 65 Coupe (Gen 3) (no additional aero mods)	= -0.3
Lotus 2-Eleven (no additional aero mods)	= -0.2
Maserati Granturismo MC GT4 (ST1 & ST2 only)(may have additional aero mods)	= -0.2
MNR VortX RT (no aero mods)	= -0.2
Panoz GTRA (may have additional aero mods)	= -0.3
Panoz GTS (may have additional Aero mods)	= -0.3
Panoz GTWC (may have additional Aero mods)	= -0.3
Porsche 991 GT3 Cup (ST1 & ST2 only) (may have additional Aero mods)	= -0.2
Porsche 996 GT3 Cup & 997 GT3 Cup (ST3) (may have additional Aero mods)	= -0.2
Pro Challenge (no additional Aero mods) (ST4 approved)	= -0.2
RSR (Renault Sport Racer) (ST3 & 4 approved with this Modification Factor only)	= -1.0
Spec Racer Ford (1 st , 2 nd , 3 rd Gen.) (ST3 & 4 approved with this Modification Factor only)	= -1.0
Thunder Roadster ('08+ Aero body/wing type) (may have additional Aero mods including wing removal) (if N/A 1.6L motor or less, ST3 approved w/ -0.0 Mod Factor)	= -0.2
Thunder Roadster GTR (may have additional Aero mods including wing removal) (if N/A 1.6L motor or less, ST3 approved w/ -0.2 Mod Factor)	= -0.4

Note: Future “Production” status approved vehicles and any associated Modification Factor will be posted on the www.nasaforums.com website or the Super Touring website.

6.5.4 Example Calculations

Example: 2006 Chevrolet Corvette Z06, with OEM transmission, on DOT-approved size 345 tires, weighing 3000 lbs, with 375 Avg rwhp:
 $3000/375 = 8.0$ (ST2)

Example: 2003 Dodge Viper Comp. Coupe, with OEM transmission, on non-DOT approved size 345 tires, weighing 3601 lbs, with 590 Avg rwhp:
 $3601/590 = 6.1$, minus 0.5 (non-DOT's), plus 0.4 (3601 lbs) = 6.0 (ST1)

Example: 2005 Ford Mustang, with dog-ring gearbox, frame/subframe/floor pan mods, on non-DOT 11” slicks, weighing 3305 lbs. with 472 Avg rwhp:
 $3305/472 = 7.0$, minus 0.2 (dog box), minus 0.4 (non-Production), minus 0.5 (non-DOT slicks), plus 0.1 (3301 lbs or greater) = 6.01 (ST1)

Example: 2005 Subaru STI (awd, 4-door sedan), with OEM transmission, on DOT-approved 282mm NSW size tires, weighing 2901 lbs, with 287 Avg awhp:
 $2901/287 = 10.10$, minus 0.3 (AWD), plus 0.3 (282mm DOT's), minus 0.1 (less than 3000 lbs) = 10.0 (ST3)

Example: 2008 Porsche 997 GT3 Cup, with OEM sequential transmission, on non-DOT size 320 tires, weighing 2700 lbs, with 397 Avg rwhp:
 $2700/397 = 6.80$, minus 0.2 (sequential transmission), minus 0.5 (non-DOT's), minus 0.1 (less than 3000 lbs), minus 0.0 (Production status approval) = 6.0 (ST1)
Same car if on size 345 DOT's at 2800 lbs and 337 Avg rwhp = 8.0 (ST2)

Example: Mazda GT tube-frame rotary with dog ring gearbox, on DOT-approved size 266mm NSW tires, weighing 2225 lbs, with 212 Avg rwhp:
 $2225/212 = 10.50$, minus 0.4 (non-Production), minus 0.5 (dog gearbox), plus 0.6 (266 DOT's), minus 0.2 (weight less than 2600 lbs) = 10.0 (ST3)

The online NASA ST/TT Car Classification Form functions as a calculator tool that can be used to assist competitors with these calculations with planning future modifications and builds.
<https://supertouring.nasaseries.com/forms-rules/>

Note: If one knows the competition weight of the vehicle, a simple reverse calculation will yield the maximum horsepower allowed for that vehicle. Begin by adding/subtracting all of the Modification Factors for the vehicle as listed above. Then use either the 6.00, 8.00, 10.00, or 12.00 ratio (depending on which class the car is being prepped for), and then subtract that number from the ratio to get the vehicles actual target Wt/HP ratio. Divide the competition weight by this number to obtain the horsepower target.

Using the 2008 Porsche 997 GTS Cup example above with the OEM sequential transmission, on non-DOT approved size 320 tires, weighing 2700 lbs:
 $-0.2-0.5-0.1 = -0.8$

$6.0 - (-0.8) = 6.0 + 0.8 = 6.8$ (subtraction of the negative number here results in addition)

$2700/6.8 = 397.06 = 397$ Avg rwhp for ST1
 $2800/8.3 = 337.34 = 337$ Avg rwhp for ST2

(Note: Watch for rounding errors that could lead to non-compliance. If one used 338 rwhp above, the result would be $2800/338 = 7.984$, which is less than 8.00:1.)

7. Dyno Testing

7.1. Dyno Testing Procedures

The following procedures apply to all vehicles being tested on a dynamometer, whether for initial classing purposes, or for technical inspection post-competition.

A certified Dyno report consists of three separate, reproducible Dyno tests for each Fuel/Timing Map or boost controller setting with SAE J1349 Rev JUN 90 correction, with the car owner's

name, car number, car year/make/model, shop name and phone number, and Dyno operator's name on the Dyno sheet, accompanied by a completed ST/PT/TT Dyno Certification Form. All Dyno tests must show horsepower and torque on the Y-axis (vertical) and engine RPM on the X-axis (horizontal) of the Dyno graph. The numerical table of horsepower and RPM (in 50 RPM increments) should be included in the report (or the competitor must use Maximum HP instead of Avg HP to calculate the Adjusted Wt/HP Ratio). An inductive pickup or other direct sensor shall be used to measure engine RPM (as opposed to obtaining RPM data from the ECU/OBD port or from calibration from the vehicle's tachometer.) If this is not possible due to vehicle configuration, the Dyno operator must note on the Dyno sheet the method used for obtaining RPM data, and the reason for not using an inductive pickup or sensor*. Dyno testing shall be done with the vehicle at normal operating temperature, with at least 28 psi tire pressure (but should be at normal operating tire pressure if higher)**, and in the gear producing the highest horsepower readings (typically the gear closest to 1:1 ratio)***. However, it is the competitor's responsibility to ensure that the vehicle is compliant with horsepower limits in ALL gears. The vehicle's hood shall be open with a cooling fan placed in front of the engine during testing. Engine, ECU, boost controller, etc. settings shall only be altered between Dyno runs in order to obtain the required additional sets of three Dyno tests for each of the alternate ECU Fuel/Timing maps and/or boost controller settings. The Dyno test with the highest peak horsepower number of the three tests will be used to determine the Average Horsepower (Avg HP) for weight to horsepower calculations.**** A smoothing factor of five (5) shall be used. All Dyno graphs must show decreasing power for 1500 rpm from the peak horsepower level, or the car must reach the rev-limiter during the Dyno testing. All horsepower measurements will be rounded to the nearest whole number.

* (note: If an inductive input or direct sensor is not used to measure engine RPM, the competitor must notify the Series Director before competition to determine if the vehicle must be Dyno tested again before competition.)

** (note: If the tire pressures during pre-competition Dyno testing are set lower than their post-competition pressures, it is likely that post-competition Dyno compliance inspection testing will yield higher Dyno horsepower results, putting the competitor at risk for disqualification.)

*** (note: It is common for BMW M3's, Honda S2000's, Mazda RX-8's, Scion FR-S/Subaru BRZ, Nissan 350Z/370Z to show the highest horsepower readings in 5th gear.)

**** (note: If a competitor chooses not to, or cannot, print out the numerical table of HP in 50 rpm increments, the Maximum Peak HP (or any number greater than the Maximum Peak HP) may be used for Adjusted Wt/HP Ratio calculations)

Any restriction device placed in the air intake system must be clearly identified as such and marked to indicate its dimensions. Vehicles that have more than one fuel/timing program or "map" in the computer/ECU/PCM must submit a certified Dyno report (3 pulls) for each of those fuel/timing "maps" regardless of which one will be used during competition. As well, the method used to switch between these "maps" must be clearly written on the ST Car Classification Form.

Dynamometer tests must be conducted on a Dynojet Model for front and rear wheel drive vehicles, and on a Dynojet, Mustang, Dyno Dynamics, or Dynapack for AWD cars, in a commercial facility that offers dynamometer testing as part of their business and is open to the public. All (AWD) Dyno test results using a Mustang or Dyno Dynamics dynamometer will have 10% added to the maximum horsepower reading to obtain the number that will be used to calculate the “Adjusted Weight/Power Ratio” (Mustang or Dyno Dynamics Dyno awhp x 1.1 = Maximum awhp for wt/hp calculation). Each Regional ST Leader may retain the option to specify which business locations will be the approved centers for that particular region. Please check with the ST Leader in your area for instructions.

Certified Dyno reports are potentially valid for up to a maximum of three years (provided that no changes have been made to the vehicle that would alter Dyno readings). However, at his/her discretion, a NASA ST Leader may require an updated certified Dyno report (at the driver/owner’s expense) after one year from the date of the previous report.

7.2 Average Horsepower Calculation

Any competitor may choose to use Maximum Horsepower instead of Average Horsepower at any time.

The number used for calculating the Adjusted Wt/HP Ratio will be a calculated average giving a better approximation of the maximum horsepower available over a range of usable RPM. For pre-competition testing, the Dyno test with the highest maximum horsepower will be used to calculate this average (not an average of the three Dyno runs) as follows (all horsepower numbers will be rounded to the nearest whole number before any calculations):

Avg HP = Average HP calculated and used in the Adjusted Wt/HP Ratio

Max HP = Maximum horsepower shown on the data export

The following sixteen (16) data points will be obtained from the Dyno’s 50 RPM data export numeric RPM/HP table printout:

Horsepower at: 250 rpm, 500 rpm, 750 rpm, 1000 rpm, 1250 rpm, 1500 rpm, 1750 rpm, 2000 rpm greater than Max HP rpm

Horsepower at: 250 rpm, 500 rpm, 750 rpm, 1000 rpm, 1250 rpm, 1500 rpm, 1750 rpm, 2000 rpm less than Max HP rpm

(If any of the above data points at higher RPM than Max HP RPM do not exist due to redline, then those potential data points will not be used in the calculation of Avg HP.)

7.2.1 For vehicles with a redline greater than 7000 rpm:

The seven (7) highest data points of the above sixteen (16) will be used in the calculation below:

$$\text{Avg HP} = \frac{\text{Max HP} + (\text{sum of the seven highest data points})}{8}$$

8

7.2.2 For vehicles with a redline between 6000-7000 rpm:

The five (5) highest data points of the above sixteen (16) will be used in the calculation below:

$$\text{Avg HP} = \frac{\text{Max HP} + (\text{sum of the five highest data points})}{6}$$

7.2.3 For vehicles with a redline less than 6000 rpm and all Forced Induction vehicles:

The three (3) highest data points of the above sixteen (16) will be used in the calculation below:

$$\text{Avg HP} = \frac{\text{Max HP} + (\text{sum of the three highest data points})}{4}$$

7.3 Dyno Compliance Inspections

Any vehicle requested to have a Dyno compliance inspection by the Race Director, National ST Series Director, or other NASA official designated by the Race Director, that is unable to complete testing for any reason, is subject to, and likely will be disqualified. At the time of the request for testing, the competitor is responsible and required to provide any special equipment necessary to Dyno test that vehicle model. Any vehicle with compliance Dyno testing showing aberrant results compared to the pre-competition Dyno testing is subject to disqualification.

Dynamometer tests are official and certified when performed by series Officials for compliance testing (without the need for a Dyno Certification Form—but must be signed by the Official). It is the responsibility of the competitor to be within power levels on any Dyno that NASA officials choose to use for testing. The Dynojet will be the preferred Dyno for all vehicles, and will be used exclusively when available. As AWD Dyno availability is limited, NASA Officials may use any of the four AWD Dynos listed above. AWD drivers need to be especially careful that their cars will be compliant on any official Dyno that is available.

For compliance testing, the Regional ST Leader (or National ST Series Director), or Race Director, or other NASA Official, and the dynamometer operator will determine: 1) which gear(s) to use, 2) how many test runs to perform for any given vehicle, and 3) what the normal operating temperature is for that vehicle. Tire pressures shall not be adjusted between the time the vehicle was on track competing and the time of Dyno testing. If the competitor violates this rule, the tires will be inflated to 40 psi before compliance Dyno testing. Prior to the dynamometer inspection the competitor may top off any fluids needed to help ensure the engine and drivetrain are not damaged during testing. The fluids must be added with a NASA Official present. No other modifications or adjustments may be made to the car. To ensure fairness, a NASA Official, or an individual appointed by a NASA Official, will operate any cars being inspected on the dynamometer. Any run that results in an erratic or non-reproducible result may be dismissed by NASA officials.*

* (note: It is common for vehicles to show increasing chassis dynamometer horsepower readings with serial Dyno runs due to increasing operating temperature of the engine and drivetrain, increasing tire temperature/pressure, and, at times, ECU map programming adjusting the fuel/timing maps dynamically. These increasing horsepower readings do not indicate that the Dyno is inconsistent or malfunctioning, or that these are erratic or non-reproducible readings.)

Vehicles may not have any adjustments during the competition day to systems that allow adjustment of horsepower levels that would serve to alter Dyno readings (unless granted specific permission by the Regional ST Leader, ST Series Director, or Race Director).

Examples of such systems are driver-adjustable electronic tuning and engine timing advance devices, fuel pump output modification devices, boost controllers, adjustable MAP and MAF voltage clamps, and any other system that could alter the Dyno readings when measured for compliance purposes.

Any hardware that allows a competitor or crew member to wirelessly or directly connect to the ECU (or alter ECU maps) at any time during competition or post-competition impound is strictly prohibited, regardless of whether such hardware is external or internal to the ECU, and regardless of the direction of data flow.

NASA has been and continues to actively conduct research on the use of in-car GPS monitoring units as an alternate method of compliance testing of horsepower output. GPS data acquisition monitoring may be used as an additional method of non-invasive compliance testing. Collected data indicating a lack of compliance may be used for disqualification when the National ST Director reviews the data and finds convincing evidence of non-compliance.

Competitors are permitted (and encouraged) to enter an Average HP on the ST/TT Car Classification Form that is higher than that showing on their certified Dyno report to allow room for Dyno variance (between the pre-competition testing done by the competitor and any compliance testing performed by ST Officials). Note that it is a procedural violation (8.4.3) any time that a Dyno test results in a higher Avg HP than that listed on the Car Classification Form, regardless of the calculated Adjusted Wt/Power Ratio.

At any event where dynamometer testing (or GPS compliance testing) is not available, ST Officials will use the Average HP entered on the ST/TT Car Classification Form along with the actual vehicle weight after competition to calculate the “Adjusted Weight/Power Ratio” for that vehicle. However, if the actual vehicle weight is less than the Minimum Competition Weight listed on the ST/TT Car Classification Form, it will be D/Q'd. At their discretion, ST Officials may have the vehicle sealed and transported for off-site Dyno testing at a later date.

At events where Dyno testing is available, ST Officials at their option will use either: a) the Average HP entered on the ST/TT Car Classification Form along with the actual vehicle weight after competition to calculate the “Adjusted Weight/Power Ratio” for that vehicle; or b) the results of Dyno testing either requested by ST Officials or performed due to a protest at the track to calculate the “Adjusted Weight/Power Ratio”. Again, if the actual vehicle weight is less than the Minimum Competition Weight listed on the ST/TT Car Classification Form, it will be D/Q'd.

Additionally, at the discretion of the ST Director, Regional ST Leader, or Race Director, the Minimum Competition Weight listed on the ST Car Classification Form may be used for the calculation if the vehicle was either not weighed in impound, or the Dyno inspection was done at a random time.

8. Forms, Inspection, Protests, Penalties

8.1. ST/TT Car Classification Forms

In order to accrue points or compete, each year/season, all NASA ST competitors must submit a current year, completed NASA ST/TT Car Classification Form and certified Dyno report to the Regional ST Leader prior to the first qualifying session of a race day. Once a form has been submitted during a season, if there are no modifications to the vehicle that would change the form, a new form does not need to be submitted at subsequent races in the same region. A new ST/TT Car Classification Form and certified Dyno report copy must be submitted when a competitor competes in a different region, or at a Championship event, or if changes have occurred to the vehicle that would change the form. Forms and Dyno reports must be submitted online here: <https://supertouring.nasaseries.com/forms-rules/> . **Furthermore, until further notice, competitors must also print out the time-stamped .pdf version of their submitted form (that will be sent to them by e-mail), and submit it and the Dyno report to their regional ST Leader or ST Race Director.** Super Unlimited (SU) competitors do not need to submit any classification forms or Dyno reports.

If a competitor needs to make any changes to the Car Classification Form or upload new Dyno information, it should be done using the “edit” link sent on the original e-mail from NASA, and the competitor should print out and submit the revised form. If the e-mail is lost, use this edit link request page <https://airtable.com/shrNZXZOq89UMg6s5>

A competitor should only have one single ST/TT Car Classification Form and Certified Dyno Report uploaded at any given time for each vehicle in each class. Older submissions will be periodically deleted from the database by NASA, but only the latest submission is valid.

No changes may be made to the Form or to the vehicle that would affect the Form after the first Qualifying competition session for the remainder of the event without the approval of the Race Director. Any approved changes will result in the vehicle moving to the back of its class (or back of the field if not gridded by class) on the pre-grid for the next race. It is at the discretion of the Race Director whether a grid position change penalty will apply if the changes are approved after a race, but before the next Qualifying competition session. Note, specifically, this rule will deter most tire type/size and weight changes once competition has started. (NASA is moving in the direction of technical inspection barcode digital identification and verification, and any changes made after competition begins will hamper this effort.)

Any ST competitor who has not submitted a completed ST/TT Car Classification Form and certified Dyno report prior to competition will be subject to one or more of the following penalties at the discretion of the Race Director in consultation with the Regional ST Leader:

1) Disqualification from the competition session; 2) Transfer to the Super Unlimited class; 3) Loss of one position place for race results, or moved to the back of its class (or back of the field if gridded by time) in pre-grid after a qualifying session (if the completed ST/TT Car Classification Form and certified Dyno report are submitted immediately upon request post-competition).

The online ST/TT Car Classification Form will automatically calculate the Maximum Avg HP number based on the competitor's input of the Minimum Competition Weight, desired class, and all other Modification Factors selected in order to bring the Adjusted Wt/HP Ratio as close to the class limit as possible, leaving as much room as possible for both Dyno variance and weight.

Competitors are permitted (and highly encouraged) to enter a Minimum Competition Weight that results in a Maximum Average HP number on the ST/TT Car Classification Form that is higher than that showing on their certified Dyno report to allow room for Dyno variance (between pre-competition testing done by the competitor and any compliance testing performed by ST Officials.) Competitors may choose to forego Avg HP calculations for pre-competition Dyno purposes, and use the Maximum Peak HP of the highest Dyno run (or a number higher than Peak HP) for Adjusted Wt/HP Ratio calculations. However, Section 7.3 still applies, and if the actual vehicle weight is less than the Minimum Competition Weight listed on the ST/TT Car Classification Form, it will result in a D/Q.

A driver may choose to compete at any time in a higher level class than would be dictated by the "Adjusted Wt/HP Ratio". A car may be modified an unlimited number of times (no power output changes during the competition day), and substitute vehicles may be used provided they comply with all ST rules. Substitution of a vehicle after qualifying sessions are completed will result in a new vehicle being placed at the back of its class (or back of the field if gridded by time) in pre-grid for the race.

8.2 Vehicle Inspection

All completed ST/TT Car Classification Forms are available on-line for review by any competing driver <https://supertouring.nasaseries.com/forms-rules/>. Super Touring vehicles are subject to detailed inspection by any NASA Technical Inspector and visual inspection by Super Touring competitors at any time when the car is at the track. Super Touring Officials retain the right to request any disassembly or other procedure required to verify vehicle compliance. At random times or at the discretion of the Super Touring Officials, any car may be ordered to report for rules compliance testing on a chassis dynamometer. All Super Touring competitors have the option to be present for official chassis dynamometer testing; however, the printed results of Dyno testing are the property of NASA, and will only be shown to Super Touring Officials, who will let the competitor know whether or not the vehicle was compliant, and may show the competitor the results at their discretion if compliant, and will show the competitor the results if non-compliant. Competitors must comply with any request by ST Officials to review and/or download ECU program "maps" using the competitor's programming hardware and software, when such equipment is used by the competitor. As well, competitors may have GPS accelerometers and/or data loggers placed in/on their vehicles at any time by Super Touring

Officials to help verify rules compliance. And, as stated above, GPS monitoring may be used in lieu of Dyno testing when collected data shows convincing evidence of non-compliance. Furthermore, engine data logged while on track may be compared to engine data logged during compliance Dyno inspection, which may result in disqualification if there are discrepancies between the two.

8.3 Protests

Protests of any competitor's vehicle, for good cause, may be filed up to 30 minutes after the completion of a race or qualifying session, with the Race Director. A specific part does not need to be specified in the protest if the protest is about power levels, but an explanation of why the vehicle is being protested is required. Any protest requesting a Dyno test of a competitor's vehicle will require the protesting competitor to submit a cash deposit in the amount necessary for NASA to obtain the Dyno test. If the vehicle is found to be compliant, the protesting party will forfeit the deposit, and it will be used to pay for the Dyno test. Frivolous and "nuisance" protests may result in some type of action against the protesting party.

8.4 Penalties

Serial non-compliance is not welcome and will be subject to harsh penalties. Penalties will be assessed as follows, although the Race Director may choose to assess more severe penalties. Any vehicle found to have undeclared driver accessible throttle position switching or multiple ECU maps or boost controller settings that does not have pre-competition submitted Dyno graphs for each map/setting is subject to disqualification.

8.4.1 Regional

Any car exceeding the minimum "Adjusted Weight/Power Ratio" for its declared class, or failing to meet the Minimum Competition Weight listed on the Car Classification Form at any time, or otherwise found to be non-compliant with the rules for the declared class, will be penalized in accordance with the NASA CCR and these rules. Competitors should optimize their listed weight and Avg HP on the Car Classification Form so they end up with an Adjusted Wt/HP Ratio at the limit for the class, leaving as much room as possible for both Dyno variance and weight.

The Regional penalty for competing with a vehicle in a class lower than that dictated by the Super Touring classification system, or failing a weight inspection, or an otherwise non-compliant vehicle, regardless of driver/owner intentions, will be disqualification for the previous race in that region for the first offence. A second offense in the same region will result in loss of half of season points, a one race suspension, and disqualification from the race. At third offense in the same region, there will be a loss of all season points and a four race suspension. Any Regional disqualification or suspension will result in zero points that cannot be dropped.

8.4.2 National

Either the Regional ST Leader or the Regional Race Director will report by e-mail all disqualifications under the above paragraph to the National ST Director, who will maintain a

record of all disqualifications for non-compliance with classing rules. The National penalty for any driver disqualified three times in one season (regardless of region) will be revocation of eligibility to compete in the NASA Championships (in any class or series—not just Super Touring). The fourth offense in two seasons (regardless of region) will result in permanent ejection from the ST (and TT) series.

8.4.3 Procedural Violations

Any Procedural Violation of the rules that is found after a qualifying session, but before a race will result in the vehicle moving to the back of its class (or back of the field if not gridded by class) on the pre-grid. Any Procedural Violation that is found after a race will result in the loss of one position place in the final results. The following are all Procedural Violations:

- 1) Failure to revise or resubmit a Car Classification Form after new assessed modifications have been made
- 2) Incorrectly assessing Modification Factors
- 3) Failure to note all modifications that require Modification Factor assessment
- 4) Failing a Dyno test (over the number listed on the Car Classification Form) by any amount (regardless of the measured Adjusted Wt/HP Ratio).
- 5) Providing any incorrect information on the Car Classification Form

9. Vehicle Appearance

9.1 Car Numbers and Class Designation

All NASA ST cars must display the car's number on both sides and the front and rear of the car. Numbers must be of a contrasting color to the car or otherwise clearly visible, at least 10-inches tall with a 1.5-inch stroke for the sides, and four (4) inches tall for the front and rear. NASA ST cars must also display a class designation on both sides and the front and rear of the car in a four-inch height in contrasting color to the car. Class Designations shall be ST followed by the group number. For example, an ST2 class competitor would display "ST2" as a class designation. Drivers are also encouraged to place their class designation in contrasting colors on the inside of their front window, so that a driver in front of them can easily determine in his rear view mirror if the cars are in his class or not. The NASA ST Series Leader may require this additional identifier, especially if there are multiple vehicles competing that are the same model and color, but in different classes.

9.2 General Car Appearance

All vehicles must be in good condition and appearance. Vehicles with excessive body damage, primered body panels, etc., are not permitted. The vehicle must meet the "50/50" rule, which means it must look undamaged and straight at fifty (50) mph from fifty (50) feet away.

9.3 Rear Brake Light Requirement

All ST and SU vehicles shall have at least one functioning rear brake light that is clearly visible during daylight conditions.

Appendix A—Technical Bulletins for Specific Models/Items

Chevrolet Corvette C5 & C6:

1) Removal of the B-pillars (and OEM arch) above the window sill lines is permitted if replaced with a NASA-legal full competition race cage. Any changes to the roof line will result in the Modification Factor assessment listed in the rules above.

2) The OEM driver side floor top layer of fiberglass and balsa wood under the seat may be removed without a Modification Factor assessment for the purpose of gaining head room for the driver. When inspected from the underside, the OEM floor pan must be unchanged, and the OEM metal supports where the seat studs attach must be unaltered.

3) The OEM balsa wood floors may have the wood removed and substitute metal flooring in the same location as the OEM wood floors with an additional Modification Factor of -0.2. It is not permitted to raise or lower the floor from the OEM height compared to the rest of the body/chassis without taking the “Non-Production Vehicle” Modification Factor. If the wood flooring is left intact, metal plating may be placed over the wood, inside the cockpit, without an additional Modification Factor.

CTSC Tires:

Continental Tire Sportscar Challenge EC-Dry tires (225, 245, 275 only) are exempt from the -0.5 Modification Factor for Non-DOT approved tires when calculating the “Adjusted Wt/Hp Ratio”. They will use the tire size Modification Factors for DOT approved tires.

(note: This Technical Bulletin and exemption will expire 12-31-2020)

Continental Tire Sportscar Challenge EC-Wet tires (non-DOT approved) may be used in ST1-4 without a Modification Factor during officially declared “rain sessions” only.

(note: This Technical Bulletin and exemption will expire 12-31-2021)

Factory Five Roadster and Backdraft Cobra:

No Modification Factor for FF Challenge “standard front air dam” or exact replica built with different material on Production status approved vehicles.

Ford Mustang:

The Ford Performance/Racing aftermarket anti-lock braking module, part numbers M-2353-A and M-2353-CA, may be used on any Ford Mustang competing in ST4, with

a -0.3 Modification Factor assessment.

Ford Mustang and BMW E-36 and E-46 M3:

"Upper sub-frame connectors" that penetrate and modify the floor pan will be assessed a -0.2 Modification Factor (seen commonly in American Iron Mustangs).

Mazda Miata ('90-'05):

The driver's side floor pan may be modified to accommodate larger/taller drivers. All modification shall be contained between the transmission tunnel, driver's side rocker, rear bulkhead and no more than 24" forward of rear bulkhead. The modification shall not extend below the factory floor stiffener/frame rail. The steel used in the modification shall be no thinner than .060". All modifications shall be welded in place. This modification shall serve no other purpose other than seating position.

A -0.2 Modification Factor will be assessed for this modification.

NASA NP01:

The NASA NP01, as driven in the NASA NP race series, compliant with **all** NP series rules, including tires (Toyo 235 x 17 RR), sealed motor, minimum Competition Weight 1725 lbs., is permitted to compete in the Super Touring 2 class (ST2) regardless of the Adjusted Weight/Power Ratio, as long as the post-competition Dyno Avg HP is 169 rwhp or less. A pre-competition Dyno test is required for any Championship event (valid for up to three years as in section 7.1 above—at the discretion of the Championship event ST Race Director and Series Director).

Nissan 350Z/370Z:

The Nissan 350Z and 370Z shall be considered the same "model" in regard to sub-frame updating and backdating in 6.2.1.1c.

Thunder Roadster:

INEX approved non-DOT tires are permitted, and do not require a Modification Factor assessment for "non-DOT tires". Tire size Modification Factors will still apply.

Thunder Roadster pre-'08 body/no-wing type:

May still compete in ST4 with the rear suspension mounting point relocations, as designated in Section 9.3.4.3 of the NASA Spec Thunder Roadster (GL) Rules:

Rear suspension may be modified to use longer rear swing arms and rear shock mounts may be moved to outside of frame. Any 3 point rear suspension is allowed. Only one fixed pick-up point allowed per radius rod end. Trailing arm radius rods are to be the same equal length. If using radius rod mounting plates, the plates will be marked at the beginning of the season by the Series Director and can only be replaced by notification and approval of the series

Director. Maximum length for radius rods (trailing arms) is 22.5.” Trailing arms radius rods may be of aluminum or steel construction with a minimum diameter of .840 & .750 respectfully. Third link must be of aluminum or steel construction with a minimum diameter and must remain within the stock pick-up point locations as delivered by U.S. Legend Cars International. Panhard bar must be of steel construction with a minimum diameter and must remain within the stock mounting location as delivered by U.S. Legend Cars International. Note: All radius rods (7.5”, 10”, 11”, 12”, 13”, 22.5”) length measurement will have a tolerance of +/- 1/8” (0.125”).

Appendix B— ST3 & ST4 BTM Aero Modification Factor non-BTM approvals

The following vehicle higher level trim models are approved for the BTM Aero Modification Factor in section 6.3 (note: any rear wing or spoiler or rear diffuser must be removed):

BMW E30, E36, E46, E90/92/93 M3

BMW E46 non-M ZHP trim level

Chevrolet Camaro SS ('10-'15)

Chevrolet Camaro Z-28 SS ('96-'02)

Chevrolet Corvette C5 Z06

Chevrolet Corvette C6 Grand Sport, Z06, ZR1 (Front Fascia only)

Ford Mustang Boss 302 ('12-'13)

Ford Mustang GT

Mazda Protégé MP3 ('01-'03)

Note: To request approval of additional higher level trim models for the BTM Aero Modification Factor, send an email request to the National ST Director, greg@nasa-tt.com.

